

**CYLINDERS WITH NON-GUIDED CARRIER (STN)**

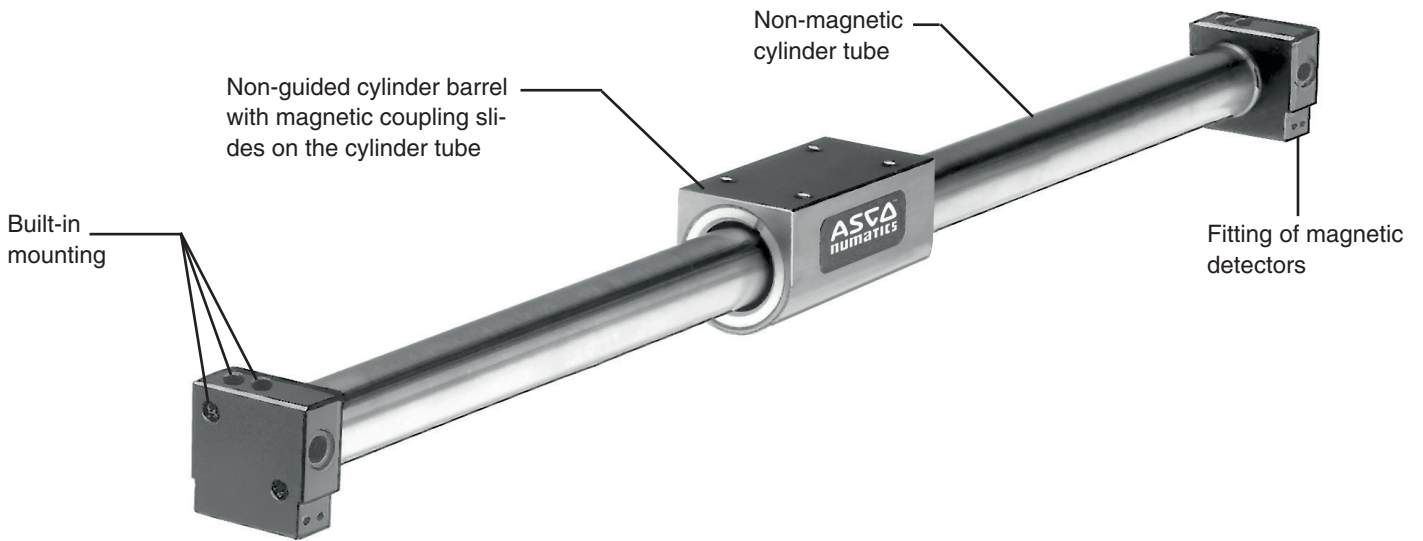

**CYLINDERS WITH GUIDED CARRIER (STG)**

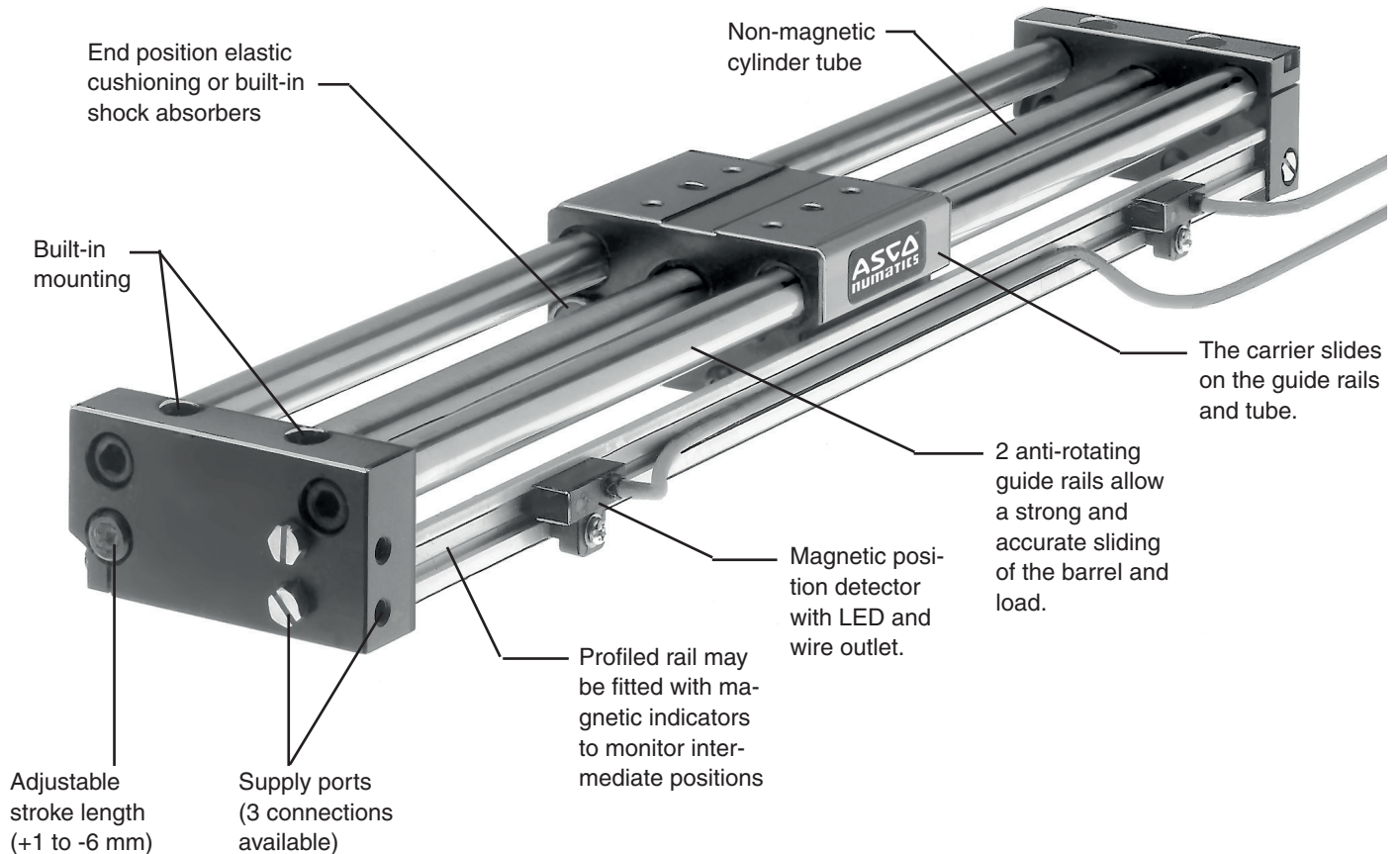

**SUMMARY**

CYLINDERS WITH NON-GUIDED CARRIER		CYLINDERS WITH GUIDED CARRIER	
• General	Page 95 ( <a href="http://www.asco.com">www.asco.com</a> )	• General	Page 101 ( <a href="http://www.asco.com">www.asco.com</a> )
• Mechanical properties	Page 97 ( <a href="http://www.asco.com">www.asco.com</a> )	• Mechanical properties	Page 103 ( <a href="http://www.asco.com">www.asco.com</a> )
• Magnetic detectors	Page 99 ( <a href="http://www.asco.com">www.asco.com</a> )	• Magnetic detectors	Page 106 ( <a href="http://www.asco.com">www.asco.com</a> )
• Dimensions	Page 98 ( <a href="http://www.asco.com">www.asco.com</a> )	• Dimensions	Page 105 ( <a href="http://www.asco.com">www.asco.com</a> )

00349GB-2017/R01  
Availability, design and specifications are subject to change without notice. All rights reserved.

**OPERATING SYSTEM**

The air-operated cylinder slides within the non-magnetic tube. The cylinder activates the carrier via the magnetic coupling by means of powerful permanent magnets.

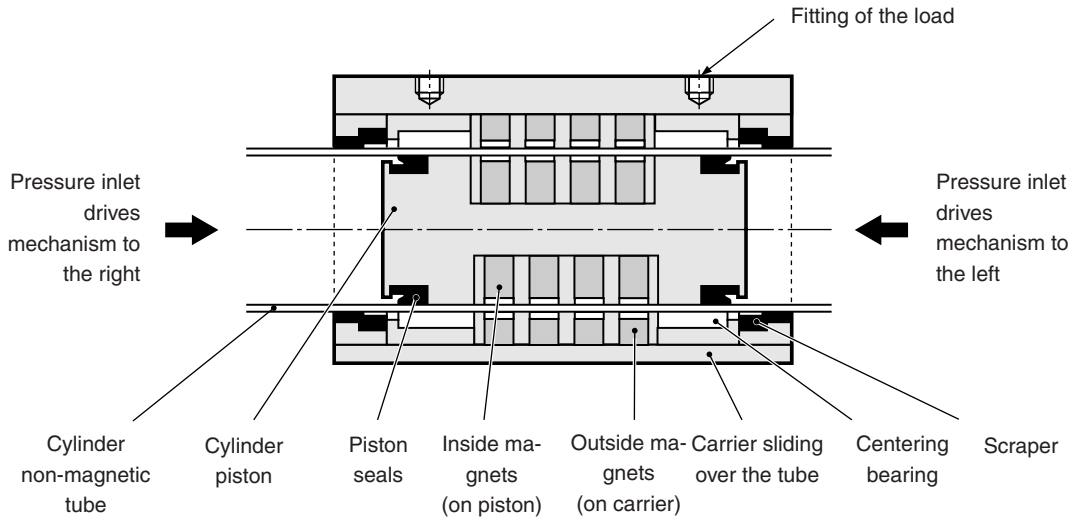

**CHARACTERISTICS**

Rodless cylinders with magnetic coupling offer many advantages :

● **REDUCED DIMENSIONS**

Unlike the traditional pneumatic cylinders, the linear drive cylinders with magnetic coupling are rodless, with reduced dimensions, an easier sliding of the cylinder within the mechanism and a different positioning of the load to move. This type of cylinder is compact.

● **EASY MOUNTING**

Cylinders are drilled for easier mounting and reduced dimensions.

● **LONG LASTING EQUIPMENT**

Due to absence of piston rod and mechanical movement, the cylinder with magnetic coupling is hermetically closed : it is thus leakage- and dust-free.

● **NON LUBRICATED AIR**

These products of advanced technology operate with lubricated or non-lubricated air.

● **MECHANICAL PROTECTION**

The linear drive is performed by magnetic coupling. In case the holding limit is exceeded, a magnetic breakaway occurs, thus offering an additional protection of the machinery and their environment. The magnetic coupling is restored when the piston and carrier align once again.

● **POSITION CONTROL**

All the cylinders are originally designed to be equipped with magnetic position detectors with ILS, LED and wire outlet.

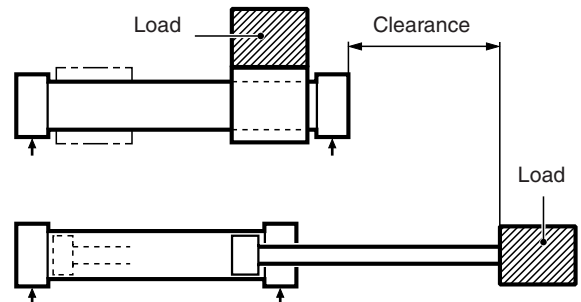

**APPLICATIONS**

Whenever space is limited or large linear drives are required such as : door opening, sliding carriers, material handling, loading and feeding, transmission over conveyors, workpieces lift (or hoist), sliding of spraying guns or cutting tools etc...

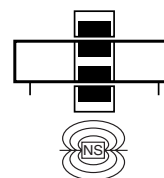

## GENERAL

**Detection** Equipped for magnetic position detectors (except Ø6)  
**Fluid** air or neutral gas, filtered, lubricated or not  
**Pressure** 7 bar maxi  
**Temperature** 0°C, + 60°C

Strokes (in mm)	Ø (mm)	6	10	16	20	25	32	40
mini	-	50	50	50	50	50	50	50
maxi		300	500	1000	1500	2000	2000	2000

## Force of the magnetic coupling

Ø (mm)	6	10	16	20	25	32	40
Force (N)	21	60	160	300	460	730	1170

**Max. allowable load** The maximum allowable load is defined by its positioning and by the cylinder specifications (see Mechanical properties).  
**Max. speed of carrier** 0.4 m/s (this upper limit avoids magnetic breakaway).  
**Cushioning** Elastic cushioning with nitrile (NBR) rings.

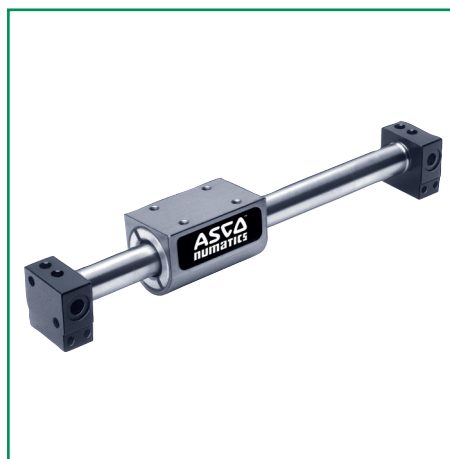

## CONSTRUCTION

**Cylinder tube** Stainless steel.  
**Front and rear covers** Anodized light alloy.  
**Carrier** Light alloy with nitrile wear rings and seals.  
**Piston** Stainless steel and light alloy.  
**Piston seals** Nitrile (NBR).  
**Magnets** Rare earths, a highly performing magnetic material.

## SPECIFICATIONS

Ø (mm)	CYLINDER WITH ELASTIC CUSHIONING		Connector Ø
	catalogue number non-cushioned	reference	
6	44550001 *	STN 6 NA .#. .	M 5
10	44550002 *	STN 10 NA .#. .-DM	M 5
16	44550003 *	STN 16 NA .#. .-DM	M 5
20	44550004 *	STN 20 NA .#. .-DM	G 1/8
25	44550005 *	STN 25 NA .#. .-DM	G 1/8
32	44550006 *	STN 32 NA .#. .-DM	G 1/8
40	44550007 *	STN 40 NA .#. .-DM	G 1/4

\* Please specify stroke length (in mm)

## ACCESSORY

### ALIGNMENT COMPENSATION BRACKET

Ø (mm)	Ø 6	Ø 16	Ø 20	Ø 25	Ø 32	Ø 40
catalogue number	88144501	88144503	88144504	88144505	88144506	88144507

**MAGNETIC POSITION DETECTOR** : see next pages

### SPECIFYING THE REFERENCE OF A RODLESS CYLINDER WITH NON-GUIDED CARRIER

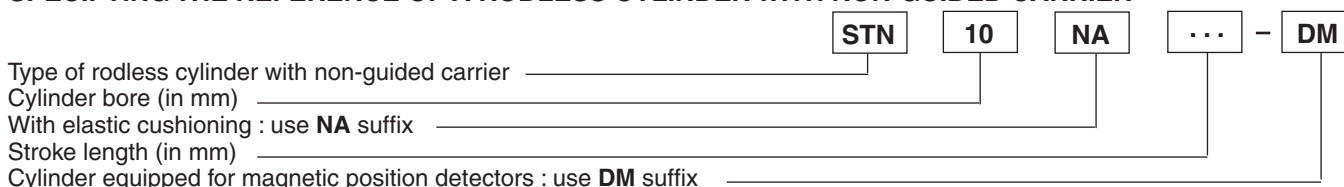

## ORDERING INFORMATION

On your order please specify : **44550002 + stroke : 200 mm** **STN 10 NA 200-DM**

Cylinder code followed by stroke length (in mm) \_\_\_\_\_  
 or cylinder reference followed by stroke length (in mm) \_\_\_\_\_

Note : Accessories and detectors must be ordered separately.

ACCESSORY - Accessory code \_\_\_\_\_ **88144 ---**

DETECTOR - Detector code and quantity \_\_\_\_\_ **88144513**

**AVAILABLE MOUNTINGS**

● **ADJUSTABLE MOUNTING**

Front and rear covers allow axial or radial mounting

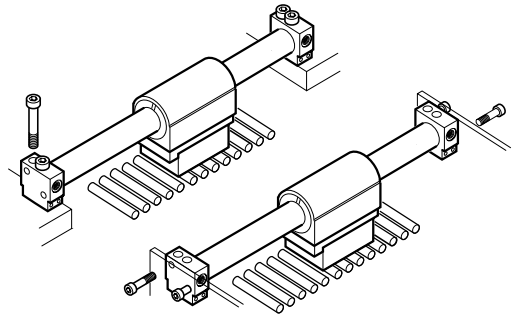

● **CHOICE OF ADAPTATIONS FOR SYSTEMS**

The carrier is rotatable up to 360° around the tube axis. The load thus may be fitted whatever the position angle. (For cylinders with magnetic position detector, see recommendations below).

The user must often fit an anti-rotating device. This type of cylinder is thus particularly recommended for the linear drive of guided loads.

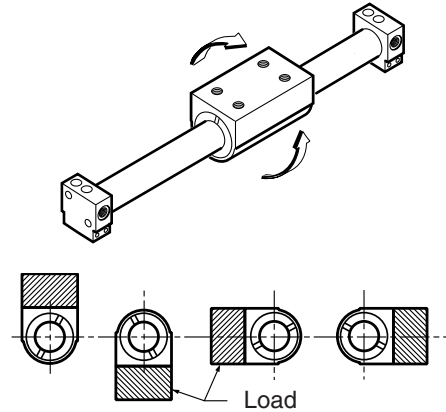

● **ALIGNMENT COMPENSATION BRACKET**

Specially designed for loads guided externally, this additional bracket (see accessories) suppresses interfering moments and frictional losses due to the misalignment of the guiding mechanism and cylinder axes.

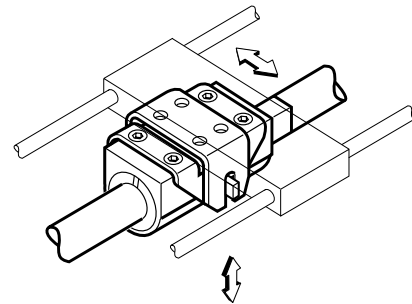

● **STROKE END MAGNETIC DETECTORS**

The cylinder is equipped for magnetic position detectors. The magnetic field of the detector coincides with the round part of the carrier.

Each detector is delivered with a mounting rail and a fitting device.

Each rail is fastened on the cylinder covers, with front or rear mounting available.

**End position sensing only.**

Possibilities of carrier adjusting according to the detector position on the cylinder end :

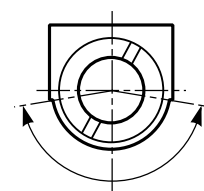

Magnetic field of the detector

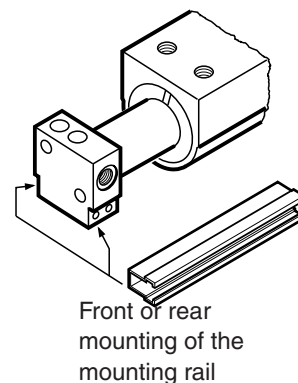
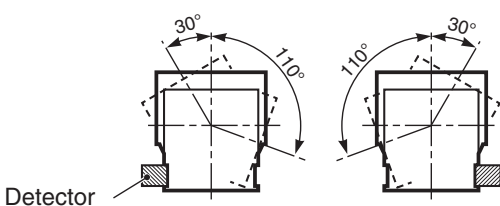

Front or rear mounting of the mounting rail

The rodless cylinder is essentially recommended for sliding loads over long strokes. The load may be positioned directly over / under the cylinder while conforming to the maximums defined according to the cylinder stroke.

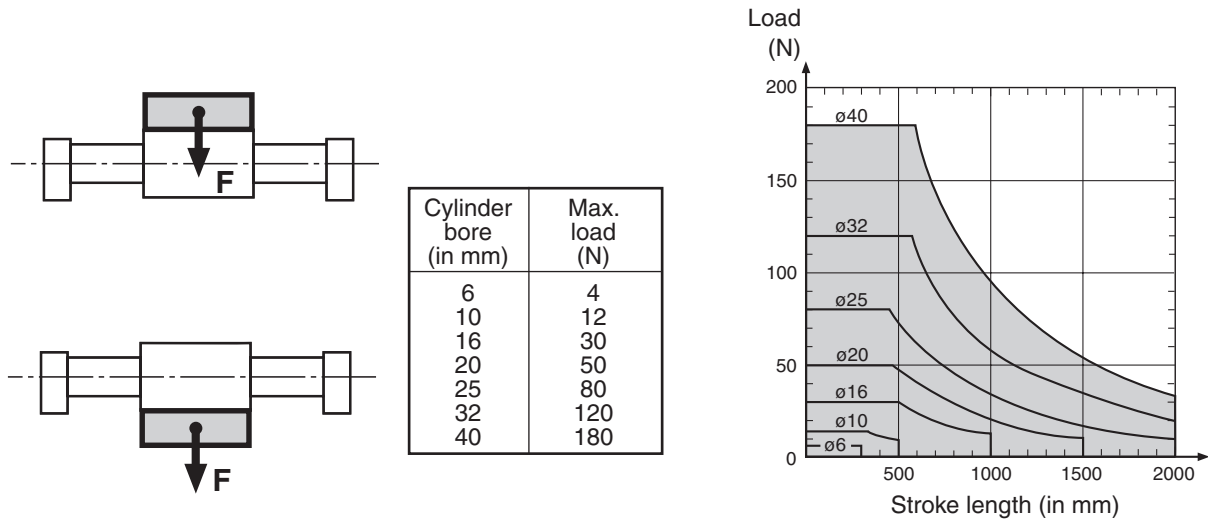

**SLIDING EXTERNAL SLIDE UNITS (HORIZONTAL MOUNTING)**

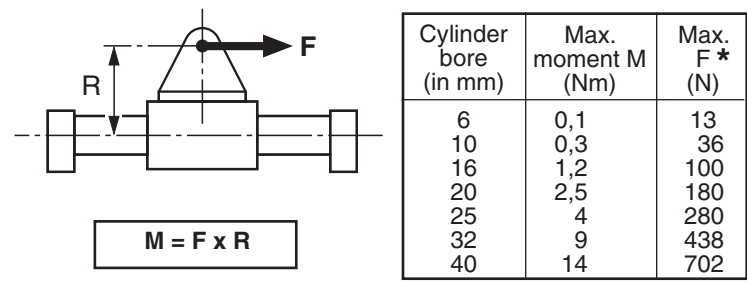

Due to linear drive and load positioning over the rodless cylinder, an effort results from sliding the load. Depending on the maximum values of moments and efforts shown in table opposite, determine the diameter of the appropriate cylinder.

\* up to 7 bar

**SLIDING EXTERNAL SLIDE UNITS (VERTICAL MOUNTING)**

In a vertical mounting, the load must be guided externally. The ratio between the total load to slide and the driving pressure is defined by the diagram below.

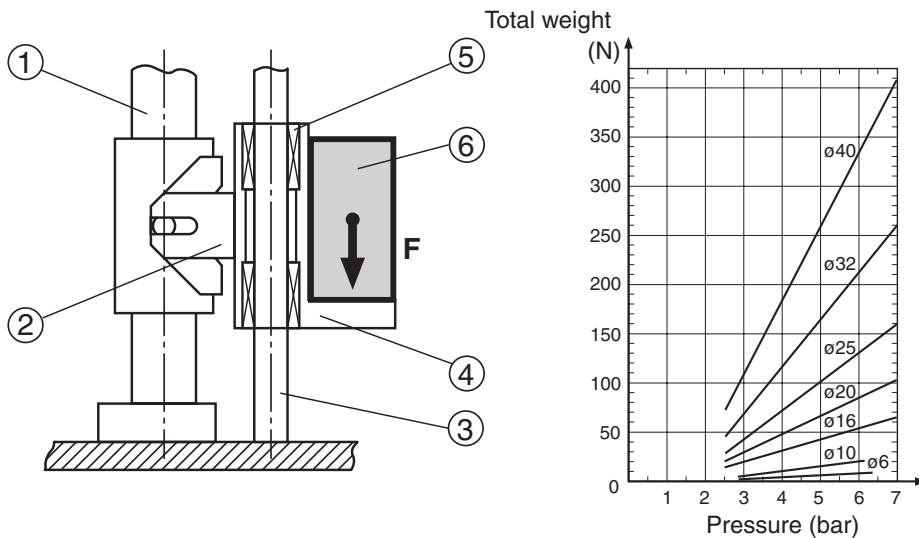

- ① - Rodless cylinder with non-guided carrier
- ② - Alignment compensation bracket
- ③ - External guide device
- ④ - Carrier
- ⑤ - External guide bearing
- ⑥ - Load

**Total weight to slide = Carrier weight + Load weight**

00349GB-2017/R01 Availability, design and specifications are subject to change without notice. All rights reserved.

**DIMENSIONS AND WEIGHTS**

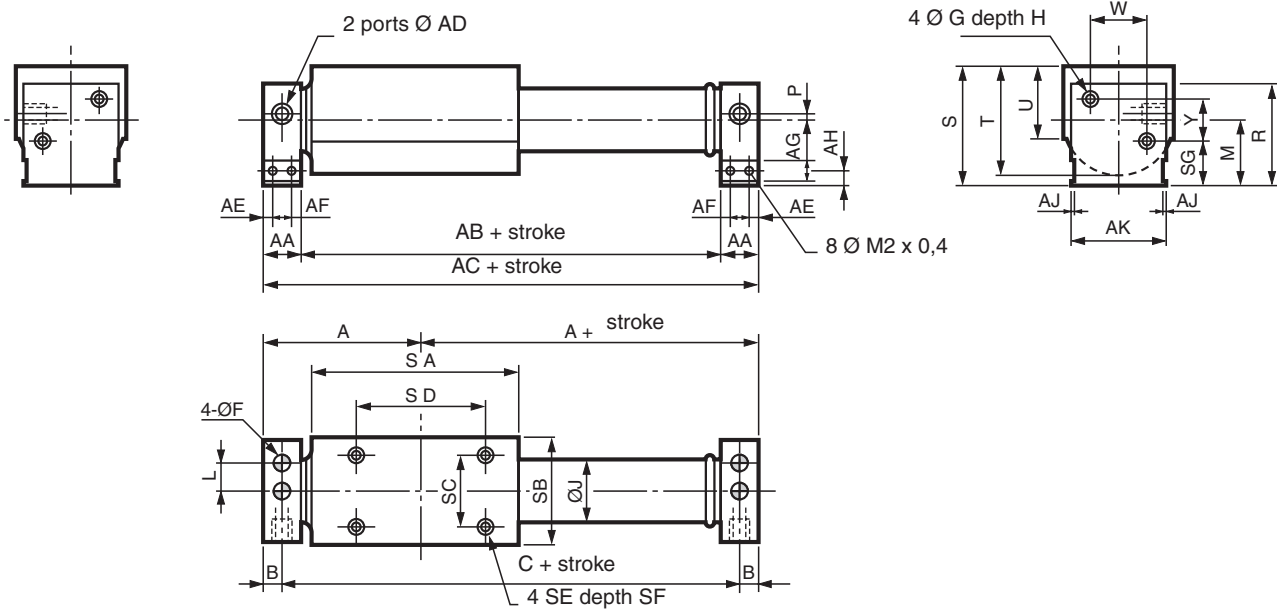

Ø (mm)	A	B	C	F	G	H	J	L	M	P	R	S	T	U	W	Y	AA	AB	AC
6	32,5	5	55	3,4	M3 x 0,5	5	6,8	4	10	0	14	18,5	17	11	8	0	10	45	65
10	33,5	5,5	56	3,4	M3 x 0,5	6	11	6,5	14	1	22	26,5	25	16	13	9	11	45	67
16	43	5,5	75	4,5	M4 x 0,7	6	17,4	8	17	0	27	32	30	20	16	12	11	64	86
20	53	8	90	4,5	M4 x 0,7	9	21,4	11	21	0	33	39	36	24	22	16	16	74	106
25	56	8	96	5,5	M5 x 0,8	9	26,4	12	23	0	38	44	42	28	24	20	16	80	112
32	64	8	112	6,6	M6 x 1	9	33,6	16	30	0	48	56	52	35	32	24	16	96	128
40	76	10	132	6,6	M6 x 1	12	41,6	18	37	0	60	69	64	43	36	28	20	112	152

Ø (mm)	AD	AE	AF	AG	AH	AJ	AK	SA	SB	SC	SD	SE	SF	SG	WEIGHTS (Kg)	
															1	2
6	M5 x 0,8	—	—	—	—	—	14	41	17	10	25	M3 x 0,5	4	5	0,050	0,006
10	M5 x 0,8	2,5	6	6	3,7	0,5	22	41	25	16	22	M3 x 0,5	6	9,5	0,110	0,013
16	M5 x 0,8	2,5	6	6	4	1	27	59	30	20	35	M4 x 0,7	6	11	0,210	0,028
20	G 1/8	2,5	11	6	6	1	32	68	36	26	40	M4 x 0,7	9	13	0,410	0,035
25	G 1/8	2,5	11	6	5	1	36	74	42	30	42	M5 x 0,8	9	13	0,550	0,047
32	G 1/8	2,5	11	6	8	2	46	87	52	38	55	M6 x 1	9	18	1,030	0,065
40	G 1/4	2,5	15	6	9	1	50	102	64	50	65	M6 x 1	15	23	1,830	0,080

1 - Cylinders weight with stroke 0  
2 - Weight to add per 100 mm stroke

**WITH ALIGNMENT COMPENSATION BRACKET (ACCESSORY)**

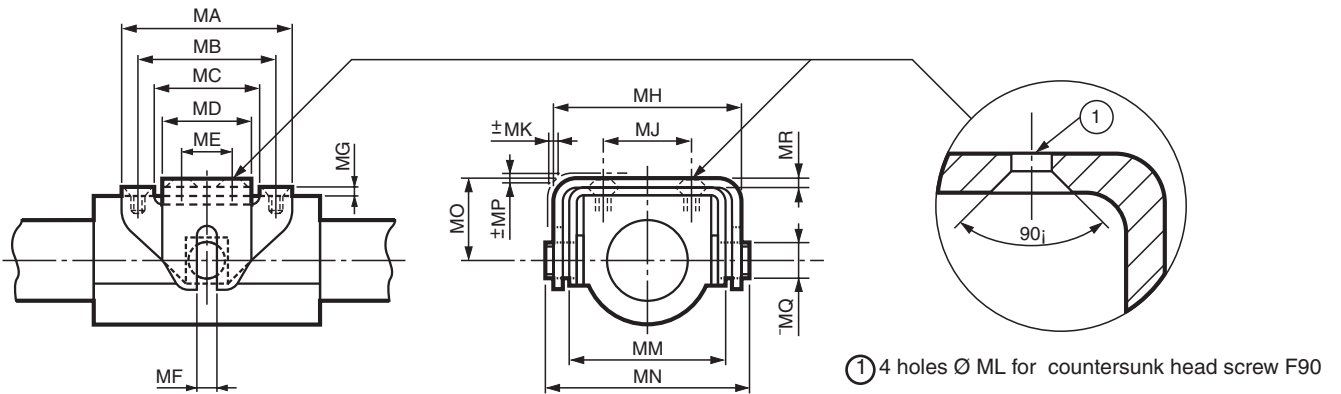

Mounting this bracket allows to compensate alignment errors between load guiding and cylinder axis :  $\pm MK$  ( $\leftrightarrow$ ) and  $\pm MP$  ( $\updownarrow$ ).  
Head screws F90 must be fitted with LOCTITE 241 on the carrier as well as on the load.

Ø (mm)	MA	MB	MC	MD	ME	MF	MG	MH	MJ	MK	ML	MM	MN	MO	MP	MQ	MR	WEIGHTS (Kg)
6	32	25	18	16	9	2	2	29	0	1	3,5	23	32	13	2	3	2	0,027
10	29	22	15	14	7	2,5	2	37	16	1	3,5	31	40	17	2	4	2	0,032
16	45	35	24	20	10	4	2,5	45	20	1	4,5	38	50	20	2	6	2,6	0,074
20	52	40	30	26	16	5	2,5	51,2	26	1	4,5	44	54	23	2	8	2,6	0,100
25	57	42	31	29	17	6	3,2	61,8	30	1,5	5,5	52,4	66	27	2	10	3,2	0,175
32	73	55	39	37	20	8	4,5	79	38	2	6,6	66	84	34	2,5	12	4,5	0,370
40	83	65	49	46	30	10	4,5	91	50	2	6,6	78	96	40	2,5	16	4,5	0,525



### OPERATING SYSTEM

A permanent magnet mounted on the rodless cylinder carrier operates on stroke end a reed switch (ILS) mounted on the cylinder cover. The detector is fitted with a warning lamp which lights when the contact is closed.

### ELECTRICAL CHARACTERISTICS

#### SWITCHING POWER

max. DC current	: 1.12 W
SWITCHING VOLTAGE	: 10 to 28 VDC (1)
MAX. SWITCHING CURRENT	: 40 mA
CONTACT RESISTANCE	: 100 mΩ
INSULATION RESISTANCE:	100 MΩ
WITHSTAND VOLTAGE	: 1000 V
RESPONSE TIME opening	: 0.05 ms
closing	: 0.4 ms
REPEATABILITY	: ± 0.1 mm
LIFE	: 5 X 10 <sup>6</sup> operations
AMBIENT TEMPERATURE	: 0°C, + 60°C
ELECTRICAL PROTECTION	: see below
HOUSING	: brass
NF C20010 PROTECTION	: IP66
CONNECTION	: 1 Ø 3 mm cable, 1.5 m long, 2 conductors 0.15 mm <sup>2</sup>
INDICATOR LAMP	: Red diode (LED) which lights when the contact is closed

(1) The indicator lamp gives a voltage drop approx. 2.5 V.

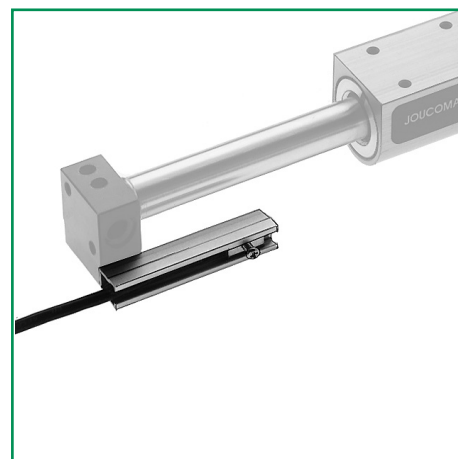

**Note : The operating point must be within the shaded zone. Any overvoltage or overintensity may damage the detector.**

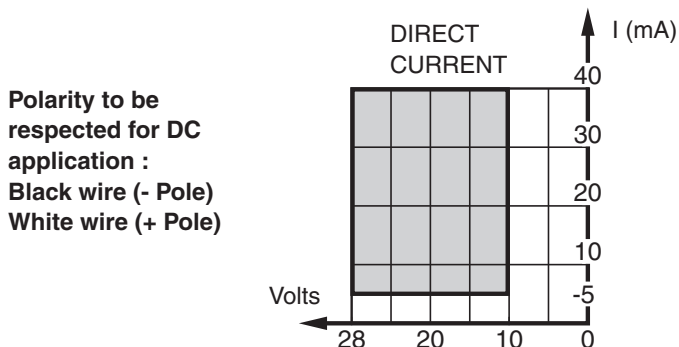

### PARTICULAR APPLICATIONS

- 1 - Detectors used for direct control of incandescent lamps :  
The power specified on the lamp is based on its resistance when hot, the resistance is very low when turned on with the lamp cold and the amperage can become very great and may exceed the ILS rating, allowance should therefore be made for the actual wattage of the bulb when cold.
- 2 - With wiring longer than 10 m, a 1000 Ω resistor must be fitted in series with the detector to reduce the capacitance effect caused by the wiring.

INDUCTIVE LOAD	 Load	100 V/1A Diode
RESISTIVE LOAD	 Load	Protection not necessary

**The user is responsible for supply and assembly of the diode.**

### DETECTOR CODE

DESCRIPTION	CODE
Magnetic position detector with reed switch (ILS) and wire outlet for rodless cylinder with <b>non-guided</b> carrier - type <b>STN</b>	<b>88144513</b>

The detector is supplied with a securing collar adapted to the cylinder diameter.

**DIMENSIONS WITH DETECTOR**

The detector must be mounted according to dimension A below. The detector position may be adjusted allowing a 1 mm overlap.

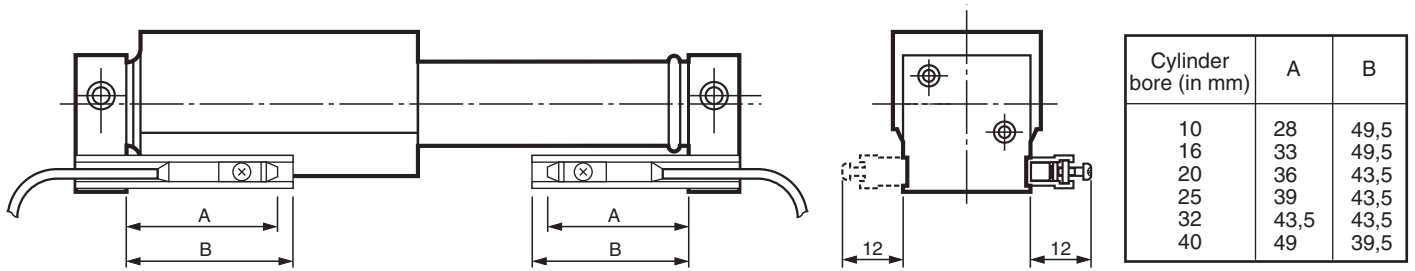

**MOUNTING THE DETECTOR**

- Fit the rail either on front or rear cylinder cover.
- Respect the directional mounting of detector with LED **inwards** and mounting instructions of parts.
- The detector is screwed into the rail by means of the locking screw.  
Max. screwing torque : < 0.2 Nm.

